

2600 SERIES VAR-E-TEE™ DAMPER

2600 SERIES DIVERTERS | Rev. 08/11/23

Elite Industrial Controls is an American manufacturer of Industrial Control Valves and Dampers. We offer solutions to Industrial Automation and thermal management solutions serving customers around the world in various industries and across several technological platforms. We are committed to providing customers with service of the highest possible level of quality.

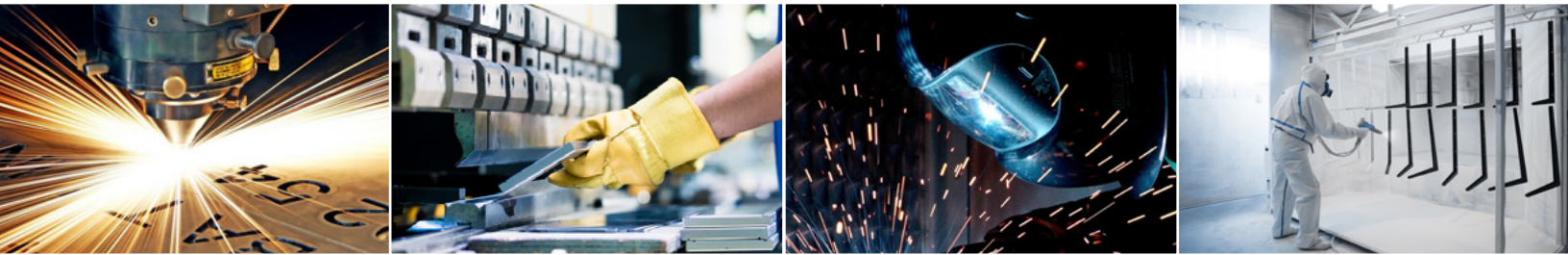

Our Var-E-Tee™ dampers are designed to give long, trouble free service in all low pressure service applications. The versatility of the fabricated Tee and Damper allows to design to your specifications as required by your systems.

- Sizes up to Ø96" (Larger and special sizes consult for quote)
- ANSI drilled flanges with various thicknesses available.
- Outboard bearing on blind end available.
- Flange thickness based on size and service.
- Rolled angle flanges available on medium duty low temperature, low pressure applications.
- Flanged or weld ends.

Operating Conditions	
Max. Temp.	Standard - 750°F, Optional - 2,100°F
Max. Static Pressure	Standard - 5 PSIG, Optional - 150 PSIG
Max. Pressure Drop	Standard - 1 PSI, Optional - 50 PSI

VALVE SEAT OPTIONS

*Leakage based on damper capacity

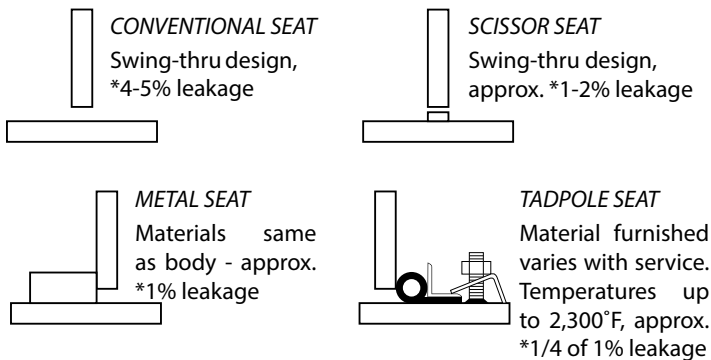

Construction and Material	
Body, Disc & Flange	Standard – Carbon Steel Optional – A-588, Stainless Steel, Exotic Materials & Refractory Lines Available on Request
Shaft	Standard – Stainless Steel Optional – Various Stainless Steel & Exotic Materials
Bushings	Standard – Carbon Graphite (3,000°F) Optional – Bronze, Teflon & Nitronic 60
Bearings	Standard – Ø72" & above (Standard with seat) Optional – Ball & roller (all sizes)
Packing Follower	Standard – Stainless Steel Optional – Same alloys as body
Lantern Gland	Standard – Stainless Steel Optional – Same alloys as body